

Spectrum Monitoring and Management System R&S ARGUS-IT

From standalone systems to completely automated nationwide networks

- ◆ Reliable solution for monitoring, management, direction finding and measurements according to ITU recommendations for stationary, transportable and mobile applications
- ◆ Compact system design
- ◆ Easy operation via intuitive graphical user interface
- ◆ Easily upgradeable
- ◆ Attractive price
- ◆ Service throughout the whole life cycle
- ◆ Controlled via Monitoring Software R&S ARGUS



ROHDE & SCHWARZ

Spectrum monitoring and management with R&S ARGUS-IT

The radio spectrum is a scarce natural resource. Being part of our environment, it has to be protected to ensure that it is used effectively.

The ever increasing demand for information and entertainment means that more and more radiocommunication systems are sharing the RF spectrum – a limited natural resource. A high standard in radiocommunications can only be achieved when all transmitting stations operate according to international recommendations issued by the International Telecommunication Union (ITU) and national regulations issued by regulatory authorities.

The only way of preventing co-located radiocommunication systems from producing mutual interference is the observation of the appropriate technical specifications and operating conditions stated in the transmitter license. If, for any reason, a station is operated without a license, ignoring license stipulations such

as frequency and output power, or causing interference to other services due to technical faults or deviation from the technical parameters given in the license, agencies such as monitoring services and broadcasters must identify the station to interdict its operation or provide the necessary assistance to eliminate the problem.



A future-oriented investment that will pay off

Tasks resulting from above-mentioned situations can be classified as follows:

- ◆ Investigation of interference due to co-channel emissions, out-of-channel emissions and intermodulation
- ◆ Monitoring of technical transmitter parameters (short-term, long-term, deviation measurements of FM broadcast transmitters)
- ◆ Field strength measurements
- ◆ Identification of unlicensed stations
- ◆ Spectrum occupancy measurements
- ◆ Planning and management of transmitters

Hardware and software are therefore required to perform and evaluate the following:

- ◆ Frequency and frequency offset measurements (ITU-R SM.377)
- ◆ Field strength measurements (ITU-R SM.378)
- ◆ Bandwidth measurements (ITU-R SM.443)
- ◆ Spectrum occupancy measurements (ITU-R SM.182/ITU-R SM.328)
- ◆ Modulation depth and frequency deviation measurements (ITU-R SM.328)
- ◆ Radio direction finding and location, listening and identification in the HF (ITU-R SM.854), V/UHF and higher frequency ranges

Rohde & Schwarz's highly sophisticated Spectrum Monitoring and Management System R&S ARGUS-IT is the perfect solution to all measurement and analysis problems related to spectrum monitoring and management. Rohde & Schwarz, the leader in this international marketplace, has consistently demonstrated this over many years.

R&S ARGUS-IT is modular, scalable and upgradeable. Therefore, a user can select a basic version according to the available budget, just starting with a core set of equipment for a modest amount outlay. A nationwide system can be created incrementally just by adding additional hardware and software modules.

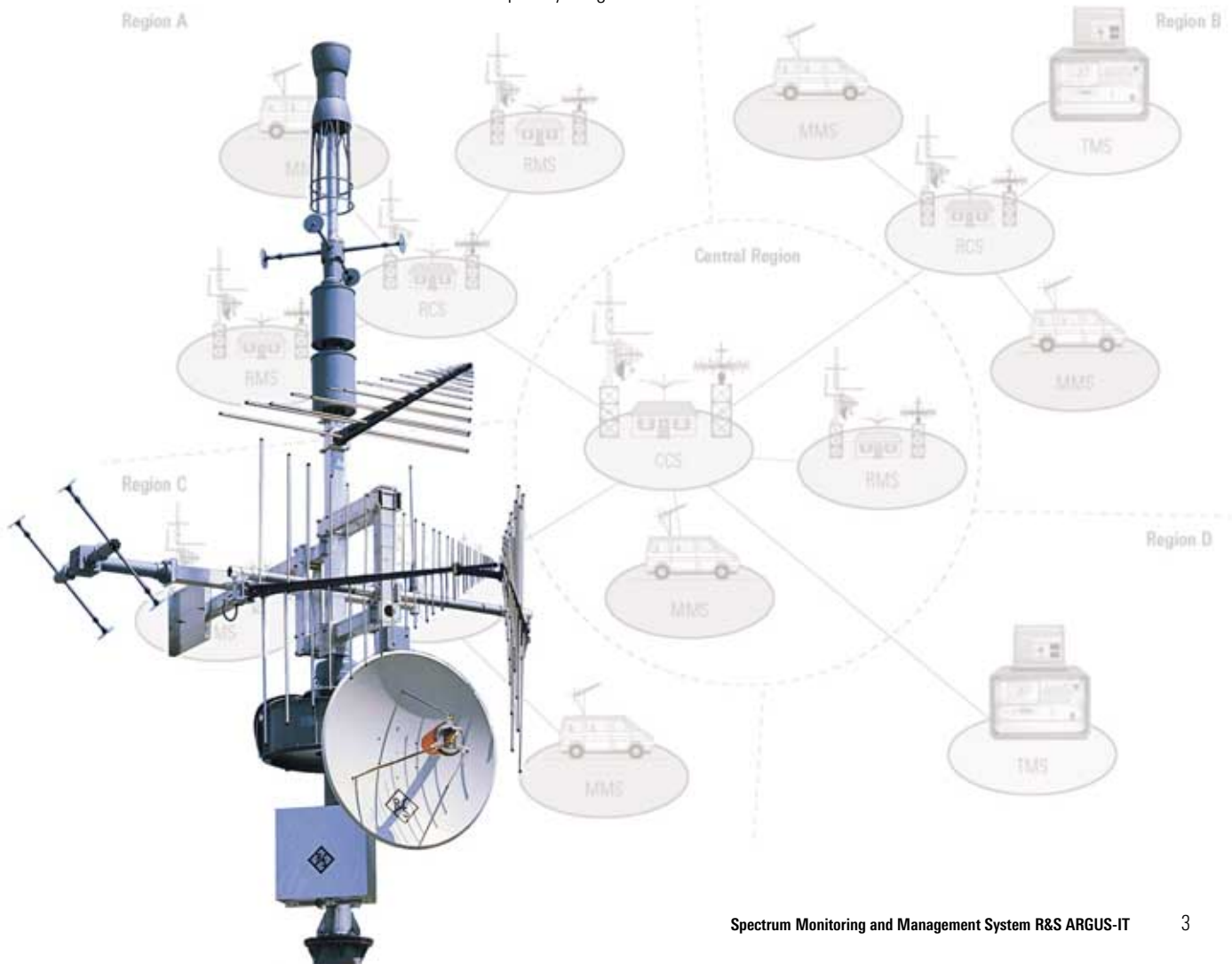

Basic system

The core of every R&S ARGUS-IT system is a set of antennas for the whole frequency range to be monitored, connected to a receiver or spectrum analyzer via an antenna selector switch. All hardware is operated by a system controller (PC or laptop) running Monitoring Software R&S ARGUS.

These measurement stations can be fixed, transportable or mobile. Thanks to R&S ARGUS-IT's flexibility, mobile or transportable systems can be equipped with the same software as fixed stations.

A lot of extensions are available to upgrade any basic R&S ARGUS-IT system whether this be to extend the range of tasks the station can perform or to improve functionality.

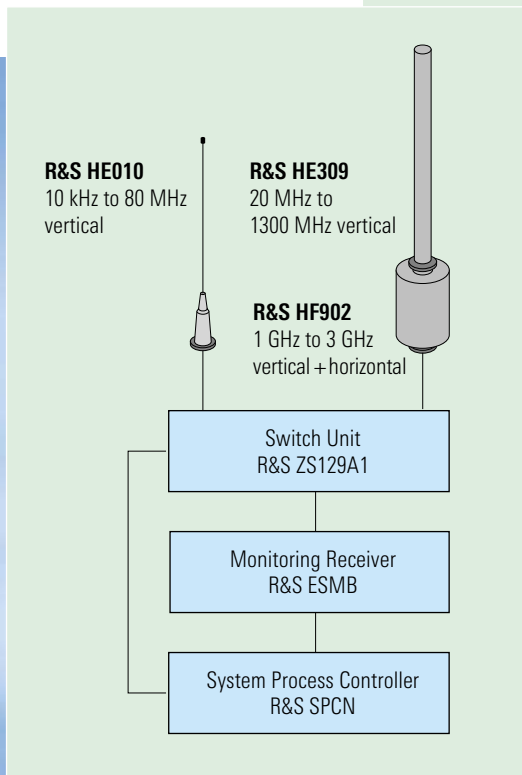
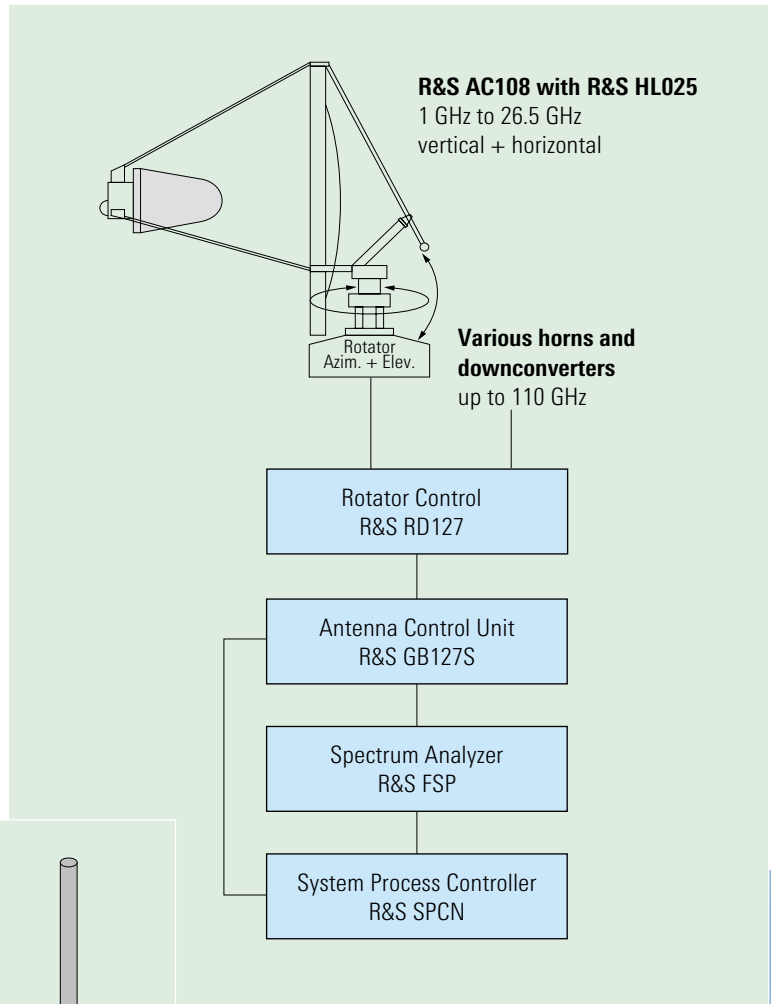

Example of basic monitoring station with R&S ESMB



A wide range of antennas

Antennas for all frequency ranges and tasks can be combined.

Some examples:

- 1 R&S HE309: 20 MHz to 1300 MHz, vertical
- 2 R&S HE010: 10 kHz to 80 MHz, vertical
- 3 R&S HK014: 80 MHz to 1600 MHz
- 4 R&S HF902: 1 GHz to 3 GHz, horizontal and vertical
- 5 R&S HE314A1: 20 MHz to 500 MHz, horizontal
- 6 R&S HF214: 500 MHz to 1300 MHz, horizontal
- 7 R&S HL023A2: 80 MHz to 1300 MHz
- 8 R&S HUF-Z1: 20 MHz to 80 MHz
- 9 R&S HL025: 1 GHz to 26.5 GHz
- 10 R&S HE500: 20 MHz to 3000 MHz, vertical
- 11 R&S AC004R1 (left): 18 GHz to 26 GHz
R&S AC004R2 (right): 26 GHz to 40 GHz
- 12 R&S HL007A2: 80 MHz to 1300 MHz, horizontal and vertical
- 13 R&S HFH2-Z2: 9 kHz to 30 MHz
- 14 R&S HL040: 0.4 GHz to 3 GHz



*Covering a frequency range from 10 kHz to 3 GHz:
Antennas R&S AU900A5 (left) and R&S AU900A4 (right)*

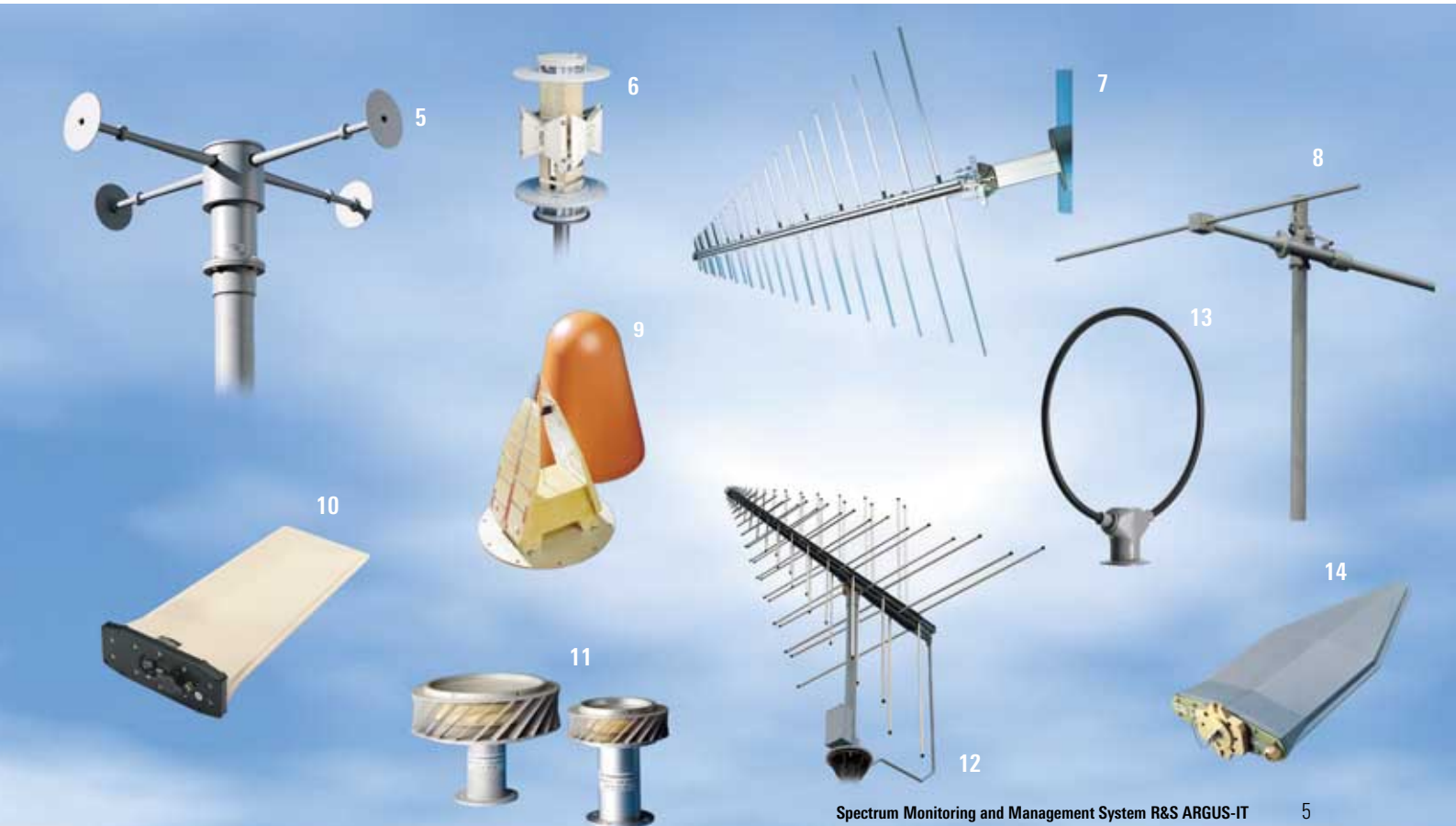

Devices ...



Digital Direction Finder R&S DDF190 with Antennas R&S ADD190 (top) and R&S ADD071 and Miniport Receiver R&S EB200 (left)

Test and monitoring receivers for different frequency ranges and tasks – for example the R&S ESMB, R&S ESMC, R&S EB200, R&S ESVN40 or R&S ESIB, spectrum analyzers like the R&S FSE or R&S FSP, signal analyzers like the R&S FSIQ or modulation analyzers like the R&S FMA or R&S FMB can be combined.



Monitoring Receiver R&S ESMB



Compact Receiver R&S ESMC



EMI Test Receiver R&S ESIB



Spectrum Analyzer R&S FSP



Spectrum Analyzer R&S FSE

... for every task

Equipment for decoding and analyzing signals such as RDS decoders or selective call decoders.

Direction finders like the R&S DDF01M, R&S DDF05M, R&S DDF06M, R&S DDF190, R&S DDF195 and R&S PA1555.

Audio and video **recording devices** such as digital recording on PC-based systems like R&S AllAudio and video recorders.

System devices like the Switch Units R&S ZS129x, Antenna Control Units R&S GB127x, Station Monitoring Unit R&S SA129, GPS Receiver R&S GPS129, System Process Controllers R&S SPCR (rackmount model), R&S SPCT (tower model), R&S SPCN (notebook) or R&S SPCC (compact model) and network equipment like routers, Communication Unit R&S GC128 or modems.



EMI Test Receiver R&S ESVN30



Direction Finder R&S PA1555



Miniport Receiver R&S EB200 with Antenna R&S HE200



Antenna Control Unit R&S GB127M



Station Monitoring Unit R&S SA129



Switch Unit R&S ZS129A1

Fixed monitoring stations ...

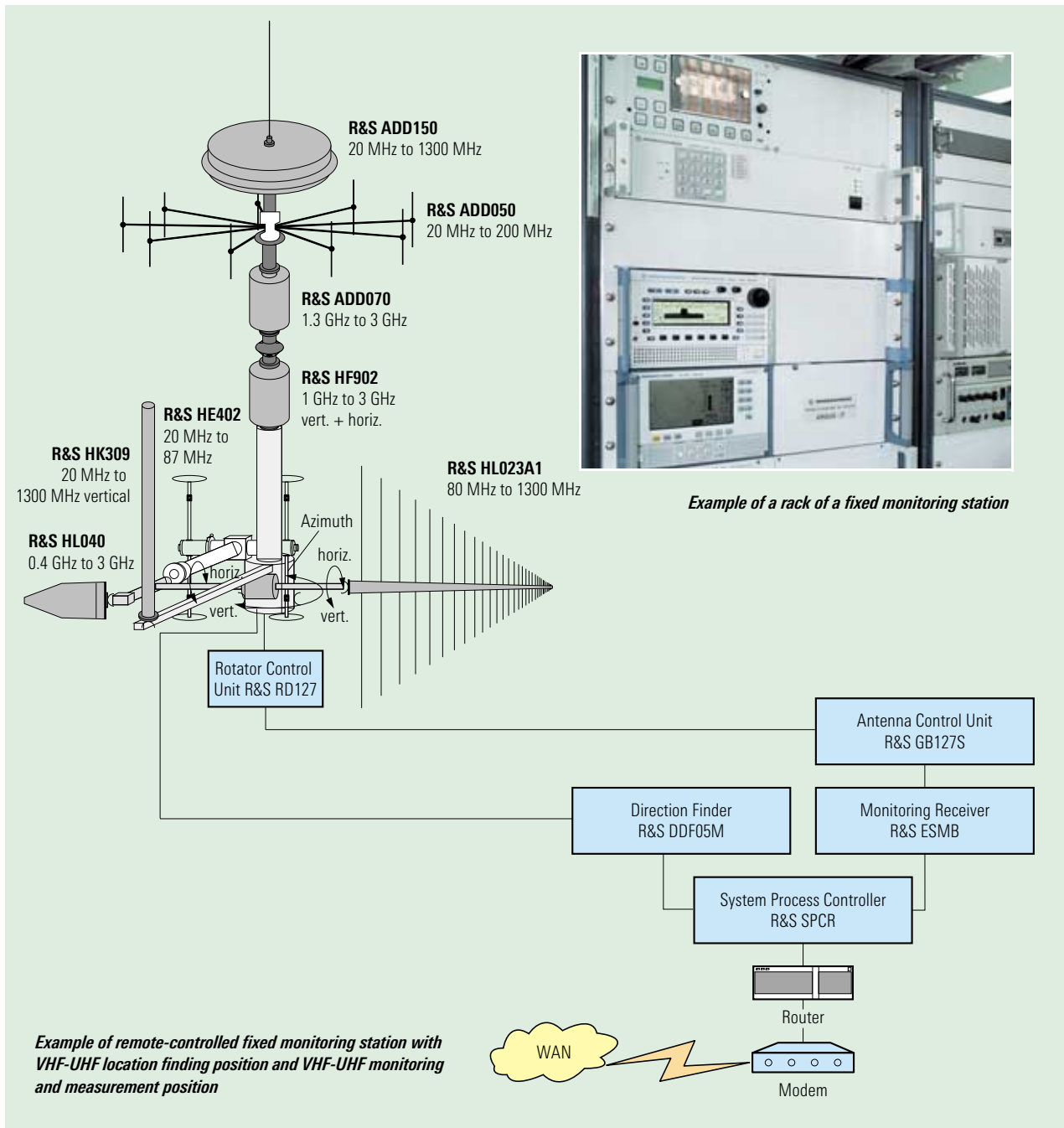

Fixed monitoring stations are the key elements of a monitoring system. All kinds of monitoring tasks can be performed in their coverage area, as there is usually sufficient space for equipment – even

large antennas – and power is always available. As it is not possible to staff all fixed monitoring stations because of the high costs involved, unattended receive and DF stations are often integrated into

the system; in many cases they are remote-controlled by the attended monitoring stations via fast network links, e.g. digital telephone lines or leased lines.

... and mobile monitoring solutions

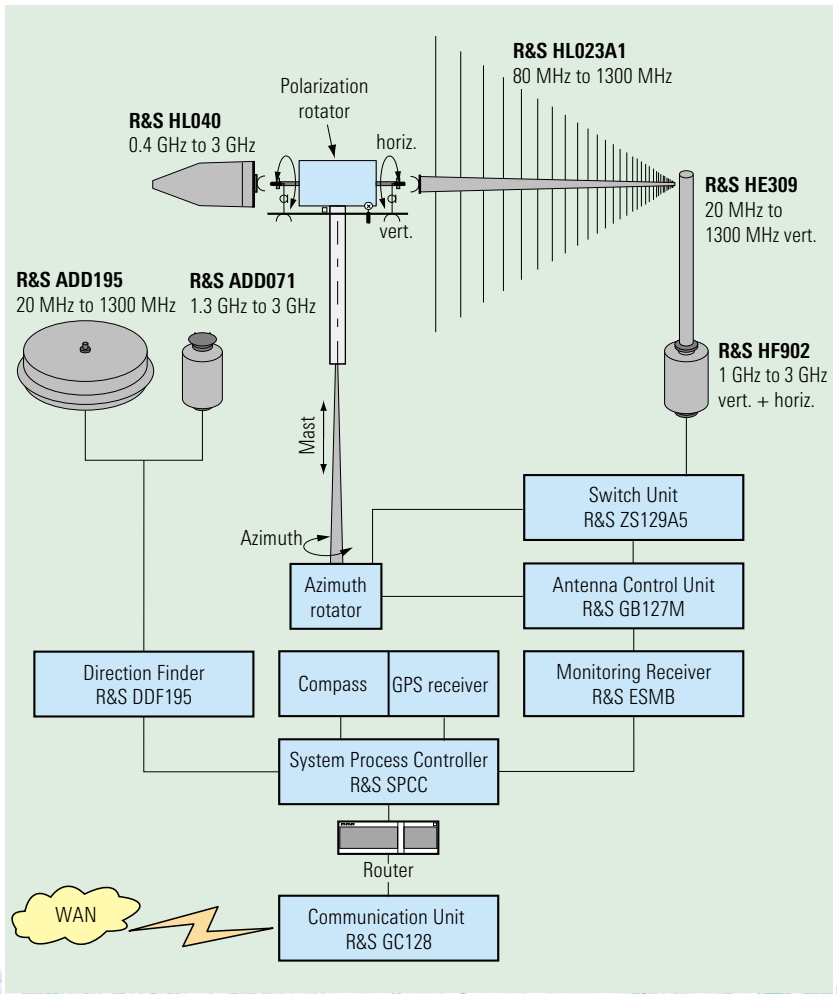

Mobile monitoring stations are mainly used for locating fixed transmitters more accurately and for homing (detection of mobile transmitters). They are also used if the receive range of the fixed monitoring stations is not adequate for the target transmitter, or if large areas cannot be covered with a sufficient number of fixed monitoring stations because the cost would be prohibitive. Jeeps or vans are the preferred platforms for monitoring stations, but automobiles or pickup trucks are also used. For special applications, monitoring systems can also be installed in helicopters, aircraft and ships.

A vehicle becomes a fully integrated mobile monitoring station, if it is equipped with a GPS receiver, a compass, a Communication Unit R&S GC128 and an optional telescopic mast in addition to the fixed monitoring station equipment.

Examples (left and below) illustrating mobile monitoring stations



Portable and transportable ...

Portable monitoring stations

Portable monitoring stations are needed to determine the exact location of a transmitter in areas where the use of vehicles is not possible (e.g. in buildings). The portable devices are, therefore, equipped with a handheld directional antenna.



Transportable monitoring stations

Transportable monitoring stations have special features so that they can be used as attended or unattended fixed stations, as mobile stations or even as portable monitoring stations.

This means that the coverage area of an existing network based on fixed and remote-controlled monitoring stations can be expanded according to user requirements in a very flexible way.

Because of their exceptional versatility, the transportable monitoring stations provide a cost-efficient alternative to fixed stations and mobile stations. Moreover, they ideally complement existing monitoring networks as their compact design facilitates fast transport and setup. Unattended measurement and monitoring can be performed for an unlimited period of time.



... monitoring stations

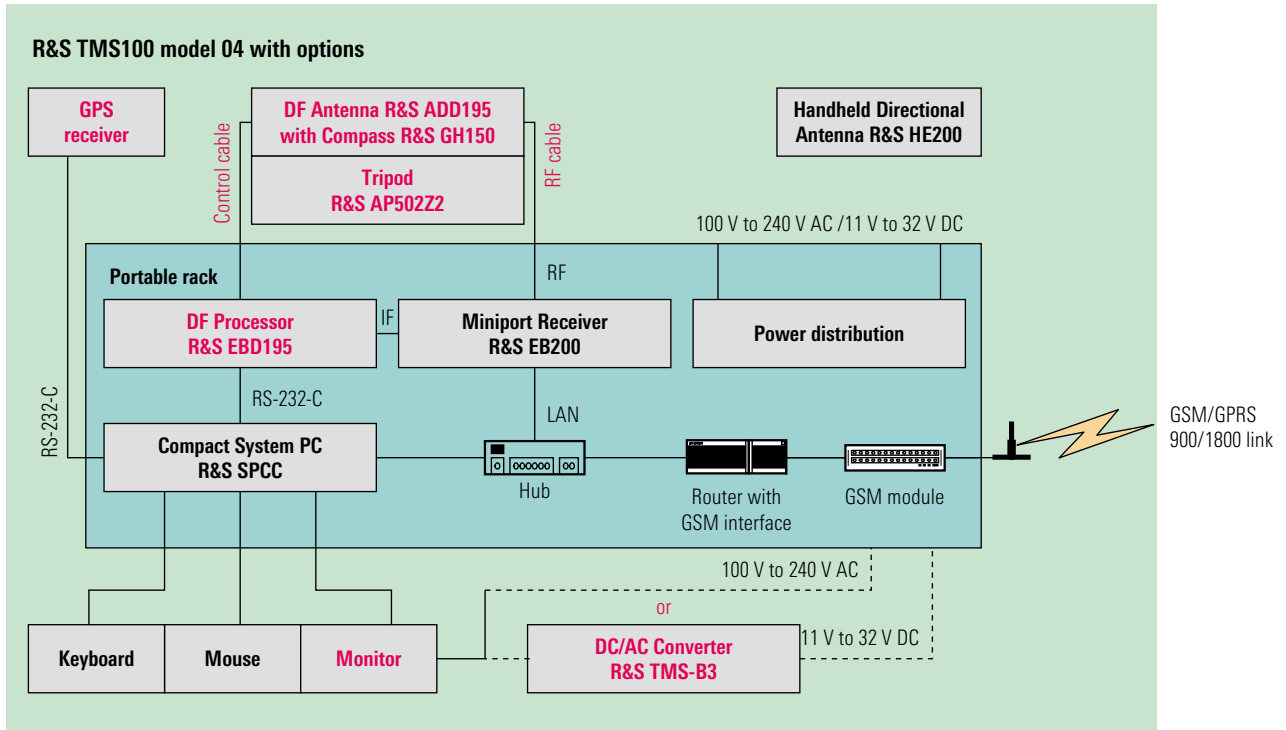

Nationwide systems

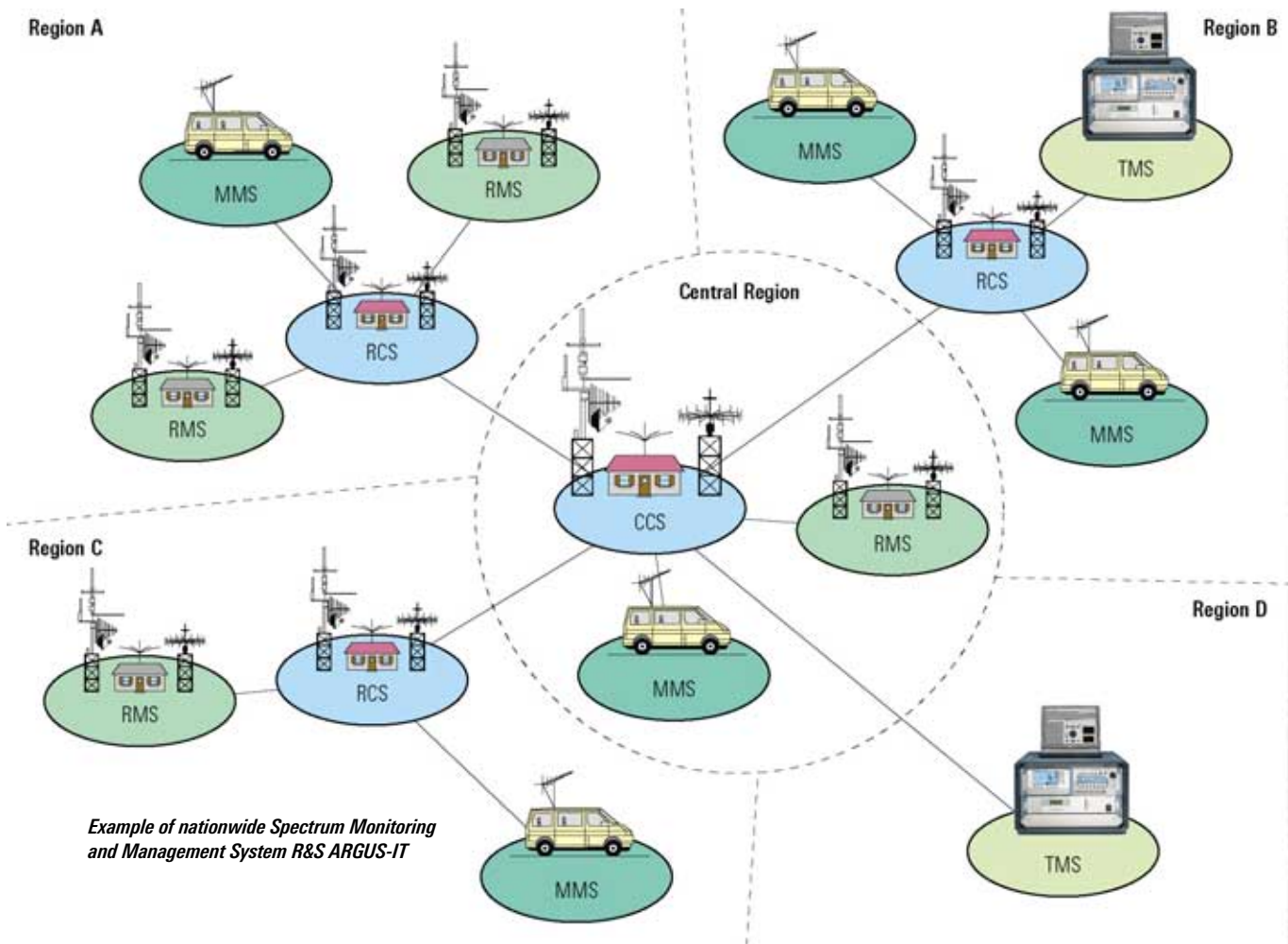

Example of nationwide Spectrum Monitoring and Management System R&S ARGUS-IT

R&S ARGUS-IT can also be used as a multistation system. Monitoring stations (fixed, transportable or mobile) can be unattended and remote-controlled. They can be connected via a local area network (LAN) like Ethernet, Fast Ethernet or Gigabit Ethernet or – more interestingly – via a wide area network (WAN) using:

- ◆ Dialed or leased PSTN (public switched telephone network) lines
- ◆ Dialed or leased ISDN (integrated services digital network) lines
- ◆ Cellular phone links with GSM (global system for mobile communications), AMPS (advanced mobile phone service) or, in the future, UMTS (universal mobile telecommunications system)

- ◆ Dialed or leased xDSL (x-digital subscriber line) lines
- ◆ Fiber-optic lines
- ◆ Packet transmission networks, e.g. X.25
- ◆ Microwave links
- ◆ Radio links
- ◆ Satellite links

For data communication, the R&S ARGUS software uses the standard TCP/IP protocol. The applications therefore use the network in a totally transparent way and independent of the network equipment, built with routers, modems, etc.

A multistation system with at least two direction finders can be used for triangulation with results displayed on digital

maps created by the Geographic Information Software R&S MapView. With a multistation system, radio- and audio-monitoring of remote stations is possible.

A nationwide spectrum monitoring and management system can easily be configured by connecting several locally installed systems. A nationwide R&S ARGUS-IT network for spectrum monitoring and management can comprise one central control station (CCS), several regional control stations (RCS), remote-controlled fixed monitoring stations (RMS), mobile monitoring stations (MMS) and transportable monitoring stations (TMS).

R&S ARGUS-IT software

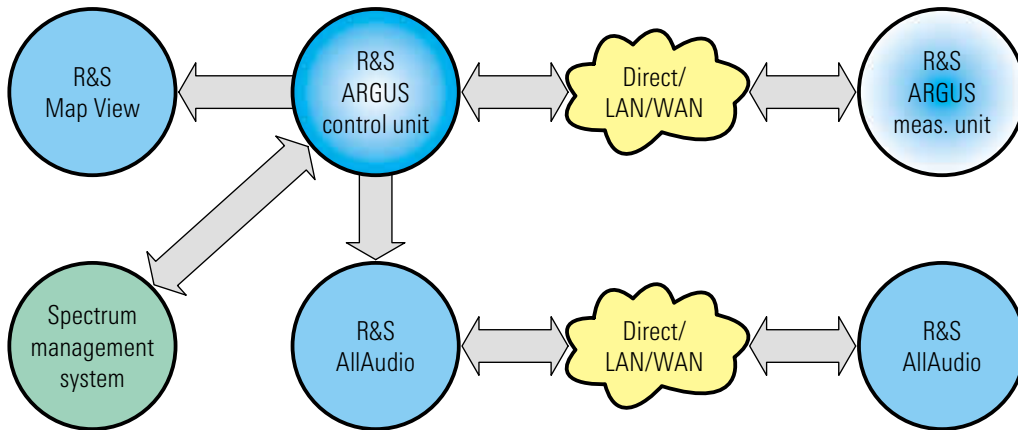

R&S ARGUS-IT software comprises the following software packages:

- ◆ Monitoring Software R&S ARGUS comprises numerous facilities for measuring, monitoring, direction finding, evaluation and report generation
- ◆ Geographic Information Software R&S MapView displays DF stations, bearing results, transmitter locations and measurement results of coverage measurements on a digital map; digital maps can be created or imported
- ◆ Integrated Digital Audio Software R&S AllAudio is a software package for digital recording, playback, mixing and distribution of audio signals; a complete intercom system is also provided
- ◆ The spectrum management system has facilities for planning and managing transmitters, billing, bookkeeping and report generation

The software packages run under the Windows XP, Windows 2000 or Windows NT 4.0 operating systems which provide ideal ease of operation, operational safety and networking. Uniform operation, preemptive multitasking and versatility in integrating additional software (e.g. MS Office) are further advantages.

Monitoring Software R&S ARGUS

R&S ARGUS is a pure client-server application comprising a measurement unit (server) and a control unit (client).

The control unit provides the R&S ARGUS user-friendly graphic user interface. This user interface can be used to configure measurement units, define measurement jobs and transfer them to measurement units, to receive, display and store measurement results and transfer these results to other applications. The control unit menu always presents the settings and measurement options of one measurement unit. One control unit can access up to eight stations simultaneously.

The R&S ARGUS measurement unit is controlled by a measurement processor which is either identical to the control processor or can be accessed via WAN or LAN. The measurement unit receives the measurement jobs from all the connected control units, coordinates them and processes them. Measurement devices are controlled and measurement results and alarm conditions are determined, buffered and transferred to the control units.

This approach has the following advantages over remote-control packages such as pcAnywhere:

- ◆ Simpler to use software
- ◆ Faster implementation of measurement jobs because only information relevant to the measurements is transferred – no need to fiddle about with files
- ◆ Cost-effective solution as the connection to the measurement section can be interrupted during a measurement, so cutting costs
- ◆ Simpler message concept as all messages can be automatically routed to the control section, if required

Measurement modes

Different R&S ARGUS measurement modes and other modules access the various monitoring, measuring and direction finding activities:

The **direct measurement mode** is used to control the measurement equipment directly via virtual control panels. This mode provides the operator with a fast way to monitor, measure, locate and identify emissions.

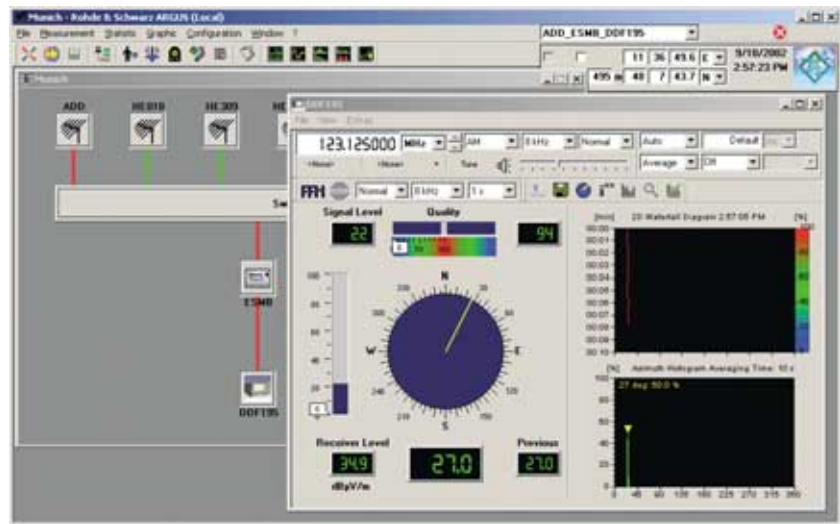

Example of direct measurement mode with Receiver R&S ESMB and Direction Finder R&S DDF195

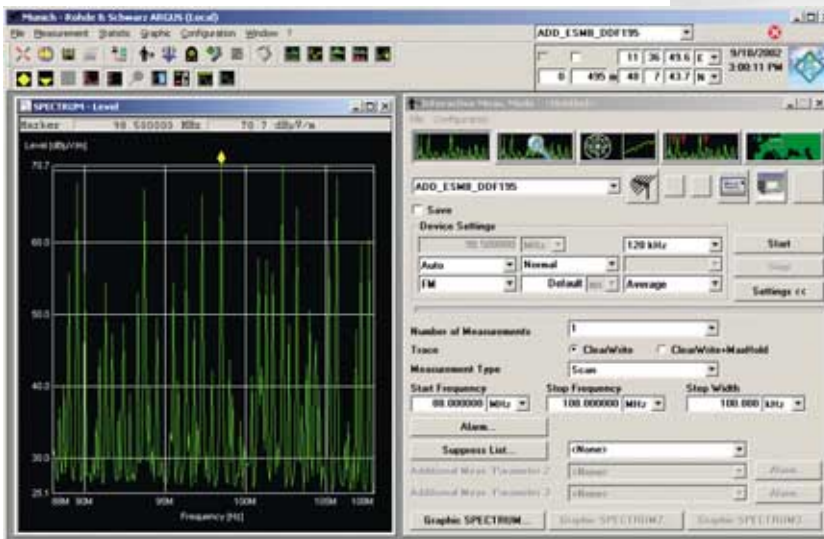

Example of interactive measurement mode

The **interactive measurement mode** is used to obtain an overview of a spectrum, for analyzing and identifying electromagnetic emissions, for obtaining results when an antenna is moved, for analyzing intermodulation and for performing coverage measurements. Intermodulation with up to three source signals is taken into account.

Example of bearing measurement mode with R&S MapView (right and below)

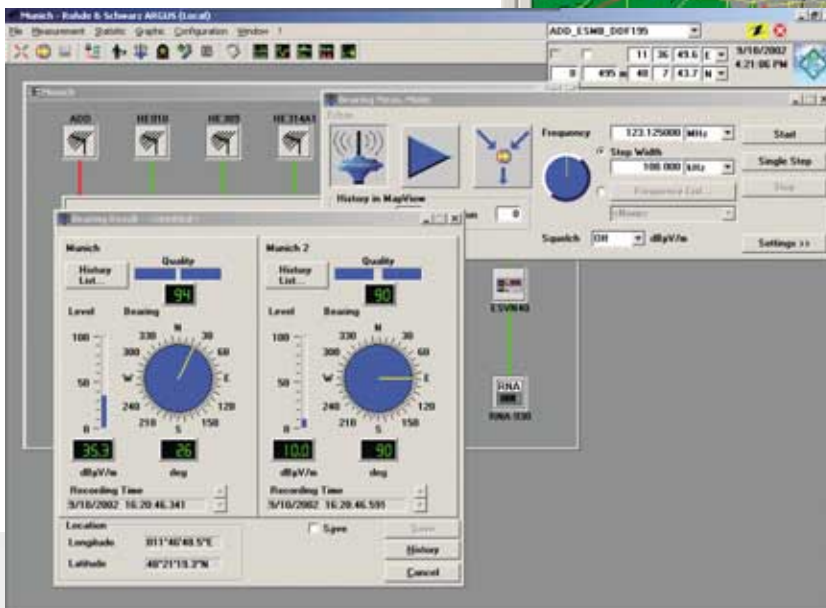
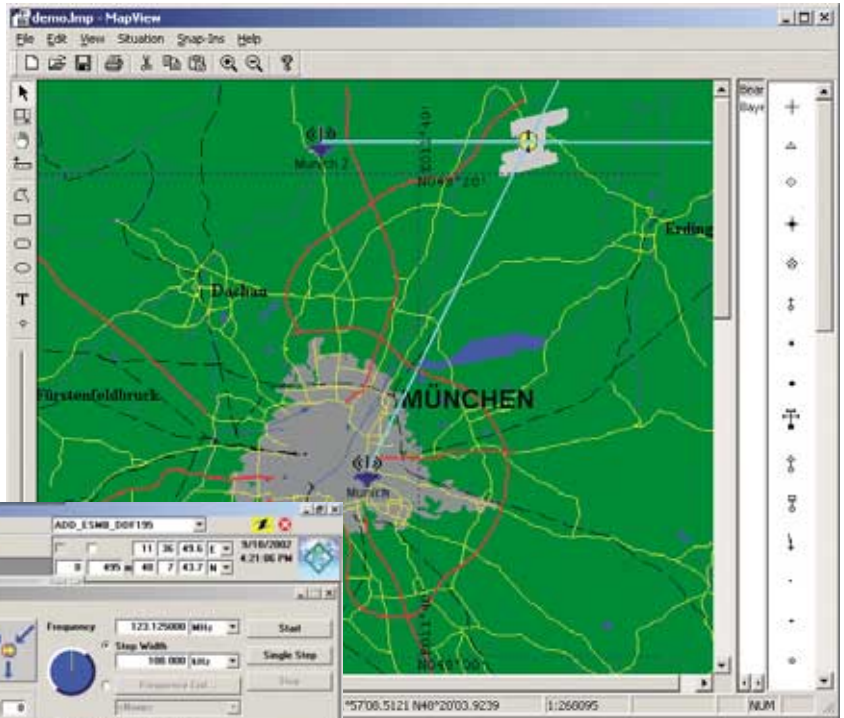

The **bearing measurement mode** is used to locate transmitters. Up to four direction finders can be controlled simultaneously. It is also possible to take running fixes and thus locate radio signals with just one direction finder (direction finding from different locations).

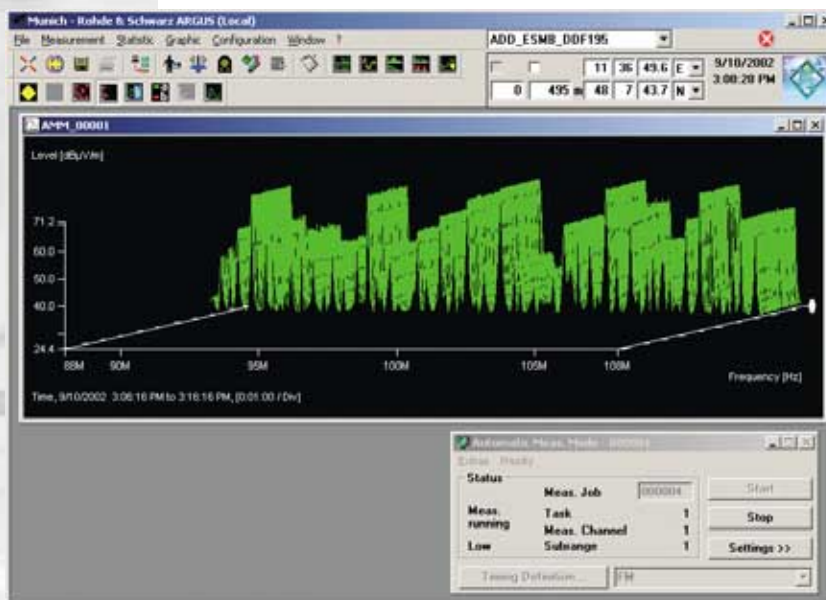

Example of automatic measurement mode

The **automatic measurement mode** is used to control all the equipment according to a schedule. The user defines the measurement tasks and starts them. The measurements are then performed automatically during the period of time defined by the user. The measurement results can be evaluated while the task is being performed or when it has been completed.

The measurement data obtained from all the measurement modes can then be processed using the **evaluation module**. This module allows a comprehensive statistical evaluation of measurement results in accordance with the standards and recommendations of ITU-R. Measurement results, their definitions and statistical analyses can also be documented in reports.

Using the **order report module** other applications are enabled to transfer measurement orders to and to receive measurement results as reports from Monitoring Software R&S ARGUS. R&S ARGUS itself can also create measurement orders and transmit them to several independent operating positions. The reports with the results are returned to R&S ARGUS.

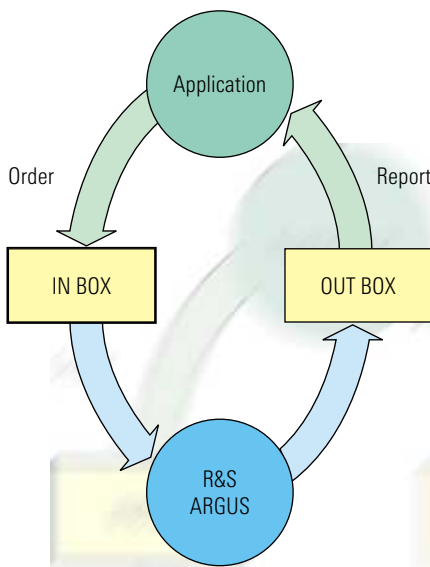

Order report concept with R&S ARGUS software

The **difference measurement module** is an addition to the automatic measurement mode. This module allows simultaneous measurements with two receivers of the same type to be performed. This feature can be used with scans (scanning from start frequency to stop frequency using frequency increments) and fre-

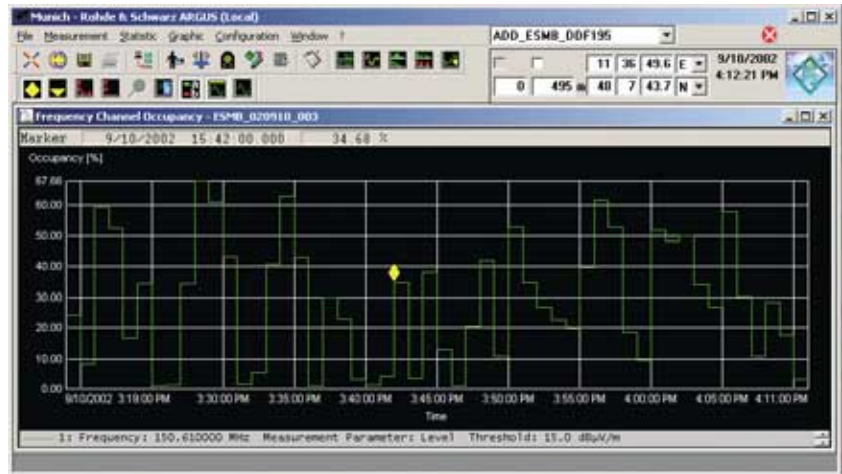

Example of frequency channel occupancy statistic

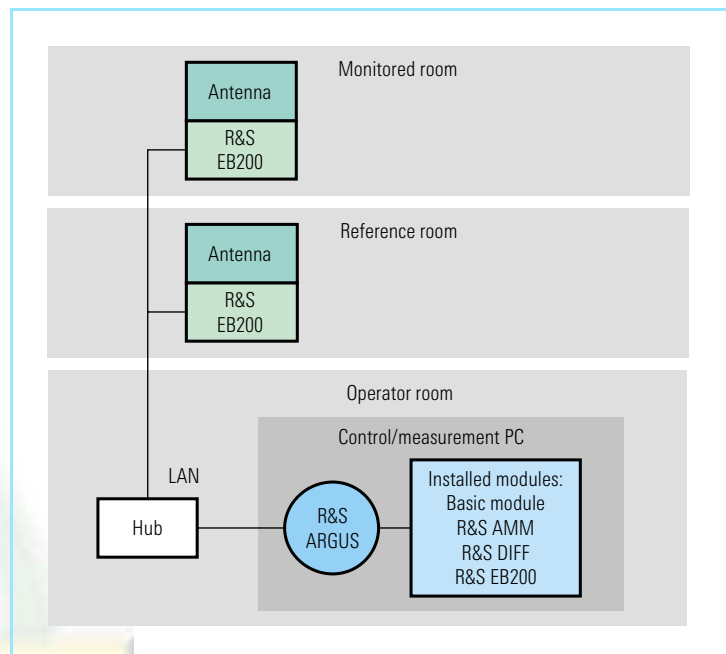

Difference measurement module

quency list scans (scanning using frequencies from a frequency list). Afterwards the difference of these measurements is calculated. The frequency spectrum of both receivers and the difference can be displayed in graphical form.

The **data exchange interface** is used to import files with frequencies, general, FM or TV transmitter data and to export

measurement results, bearing results, measurement processes and all types of transmitter lists to files. The files can be in dBase, Excel, text, comma-delimited ASCII, Access and html format. Frequency channel occupancy data can be exported to files in comma-delimited ASCII format. In addition, printouts can be made in RTF format.

Geographic Information Software R&S MapView

R&S MapView is used to display direction finding and radiolocation results on digital maps. The transmitter-site display supports DF evaluation. Another application is displaying results obtained by coverage measurements.

The R&S MapView software is used to display geographic data on digital vector and raster maps. It was primarily designed for radiomonitoring and radiolocation applications and this is why the online result display is fast and has features optimized for this task. The digital maps are easy to work with by virtue of the range of functions that are available, for example:

- ◆ Fast map zooming
- ◆ Measurement of distances and directions
- ◆ Direct selection of map objects as well as direction finding and radiolocation results
- ◆ Rapid finding of map objects by means of the tree next to the window

Integrated Digital Audio Software R&S AllAudio

With the digitization and distribution of all audio signals within a monitoring system, audio cabling and integration of switches/multiplexers for audio distribution within a local system or to remote systems are a thing of the past.

On the workstation of a monitoring system, R&S AllAudio handles the acquisition of the analog and digital audio signals from connected receivers, direction finders etc and from the workstation's microphone.

These signals may be recorded to hard disk, switched to analog output channels (e.g. for analysis) and may also be distributed to all workstations connected to the LAN or to other workstations or LANs connected via WANs.

Distributed audio signals from connected workstations are selectable for live listening-in or offline playback.

To provide communication between stations, an intercom subsystem is also integrated within R&S AllAudio, which makes use of the operator headset and/or speaker.

Spectrum management system

Integration of spectrum management and radiomonitoring is a crucial task. Our systems provide optimum efficiency by combining the latest in radiomonitoring equipment with the best-suited and powerful spectrum management software. *)



Integrated Digital Audio Software R&S AllAudio

*) We recommend integrating the spectrum management system from LS telcom AG. This system has already been used in many nationwide monitoring and management systems in conjunction with products from Rohde & Schwarz. Other spectrum management systems can also be integrated.

All services from one source

In compliance with customer requirements, Rohde & Schwarz supplies complex systems from a single source. The company views itself as an expert supplier of systems with structures and processes that are adapted to the tasks to be accomplished. This is why Rohde & Schwarz provides warranted customer service throughout the whole life cycle of any R&S ARGUS-IT system. This service comprises:

- ◆ Advice on the optimal adaptation of the system design to customer-specific tasks
- ◆ On-site selection of suitable locations for the fixed stations
- ◆ Acquisition, supply and installation of complete fixed stations with air conditioning, racks, alarm system and uninterruptible power supply
- ◆ Acquisition, supply and installation of antenna masts
- ◆ Vehicle acquisition and fitting with air conditioning, racks and masts
- ◆ Acquisition and integration of devices from other suppliers

- ◆ On-site installation and integration test of the system
- ◆ System operator training
- ◆ Special training courses, e.g. relating to the operating system or to database applications
- ◆ Customer-specific support and maintenance concept for hardware and software

A tradition of cooperation

As a member of ITU, Rohde & Schwarz is always well informed of current developments and plays an active role in the preparation of new recommendations. Aware of future developments while they are still in the planning phase, we are well positioned to design solutions that fully meet our customers' future needs, safeguarding the future value of their long-term radiomonitoring and frequency management investment.

Further information

Further information on instruments and software is available on the Internet at **www.argus.rohde-schwarz.com**, or from your local Rohde & Schwarz representative.

Information can also be obtained by e-mail to **argus@rohde-schwarz.com**.

Ordering information

Contact your nearest Rohde & Schwarz sales office for system offers.

Certified Quality System

ISO 9001

DQS REG. NO 1954

Certified Environmental System

ISO 14001

REG. NO 1954



ROHDE & SCHWARZ

ROHDE & SCHWARZ GmbH & Co. KG · Mühlendorfstraße 15 · 81671 München · Germany

P.O. B. 80 14 69 · 81614 München · Germany · Telephone +49 89 4129-0 · Fax +49 89 4129-13247 · www.rohde-schwarz.com